

# SINCE 2012 Sudarshan Gears has been providing lifting solutions using Screw Jacks.

Sudarshan Gears Worm Gear Screw Jacks lift and position loads with a manufacturing range of 0.5 Tons to 100 Tons. These Screw Jacks are designed to hold the Loads in the lifted position as they have a Self Locking feature which gives it a distinct advantage over Hydraulic Systems. Sudarshan Gears can provide several variations for the screw jacks giving tremendous flexibility to machine designers and users. Some of the variations are given on the next page.

## Design Features



### Screw Jack Casing

The Casing is made from High Strength Ductile Cast Iron giving it flexibility to absorb vibrations while carrying the load and the rigidity of high strength casting.



### Worm Shafts

Worm Shafts are manufactured from Case Hardened Steel with High Case Hardness. The threads of the Worm Shaft are Profile Ground for high surface finish thus reducing friction losses with the Worm Wheel



### Worm Wheel and Nut

These are made of Centrifugally Cast Phosphor Bronze giving high wear strength to the wheel teeth and threads of the nut. The Teeth are accurately cut on Hobbing Machines with Special Hobs to match the Worm Profile to give high load carrying capacity.



### Screw

The Screws are made of High Quality Hardened Alloy Steel machined on High Accuracy Thread Milling Machines giving high repeatability and positioning accuracy. The Screw threads are of Trapezoidal section giving optimum balance of Efficiency, Bi-directional Load Carrying Capacity and Accuracy. Screws can be made with different thread profiles on request depending upon the application.



### Protection Tubes

Protection Tubes are provided as standard for Translating Screw Type of Screw Jacks to protect the screws from damage and safety of operators as well as protect the greasing of the screw from dust. As a standard the Protection Tubes are of High Strength ABS Plastic to reduce the weight and give adequate protection. Steel Protection Tubes can be provided where the application demands.



### Bellows

Bellows are provided as a standard feature. Bellows provide dust and environment protection to the Translating Screw / Moving Nut . The bellows are made from high strength fabric as a standard. Other materials can be provided on request.



### Lubrication

The Screwjack is supplied fully lubricated with Liquid Grease of working temperature range of -5 to 110°. The Screw is also lubricated to give higher working efficiency.

## VARIATIONS

Basically Screw Jack can be selected from the following 3 Basic Types depending upon the Application

### 1 TRANSLATING SCREW

In this type the Screw moves upon and down. The Screw rotation is restricted by connecting it to the load which will have restriction in the rotating motion by linear guides or other locking method.

### 2 KEYED DESIGN TRANSLATING SCREW

This type is used when it is not possible to restrict the rotation motion of the load to which the screw head is connected. The rotation motion of the Screw is locked by a Key fixed to the Screw-jack Housing and inserted into a keyway milled into the length of the lifting screw which forces the lifting screw to translate without rotational motion.

### 3 TRAVELING NUT DESIGN

This type has a Screw which rotates and there is an External Nut which moves Up and Down when its rotation motion is restricted by the connected load.

## MOUNTING VARIATIONS

TYPE 1  
DESIGN A

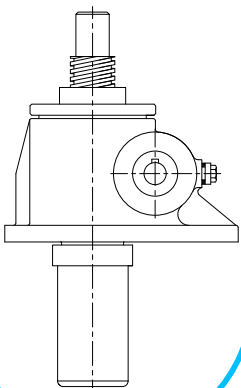

TYPE 1  
DESIGN B

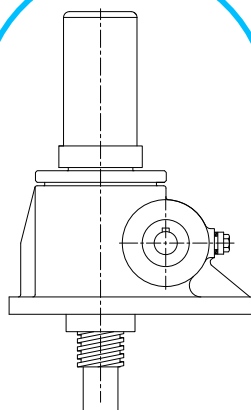

TYPE 2  
DESIGN A

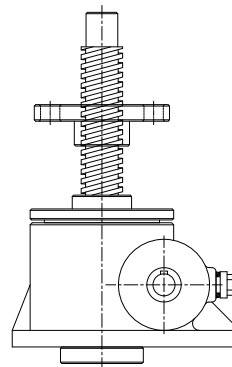

TYPE 2  
DESIGN B

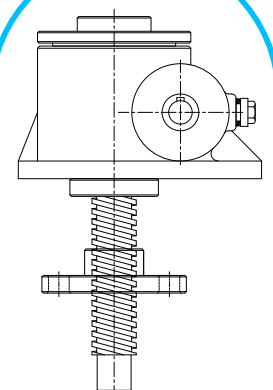

## SCREW HEAD VARIATIONS

Type I  
(Plain)

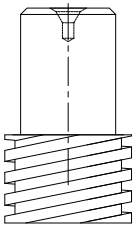

Type II  
(Flange)

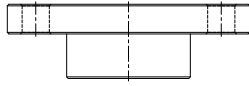

Type III  
(Threaded End)

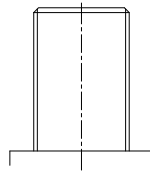

Type IV  
(Clevis End)

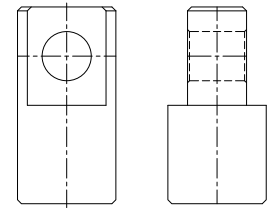

## SPEED (RATIO) VARIATIONS

There are 2 possible Variations of Speed. High Speed (H) i.e. Low Ratio and Low Speed (L) i.e. High Ratio. It takes more power to lift the same load at High Speed than at Low Speed.

## MATERIALS (MOC)

The Screwjack Housing, Screw and Worm Shaft can be made of Stainless Steel (SS) on request. These Screwjacks are used in Wet, Corrosive or Harsh environments. Appropriate Grades of Stainless Steel can be selected to provide adequate corrosion protection as well as have adequate strength to lift the load.

## ACCESSORIES

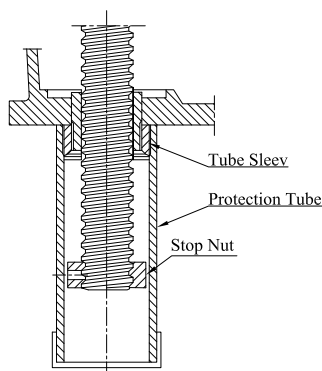

Stop  
Nut

Limit  
Switch

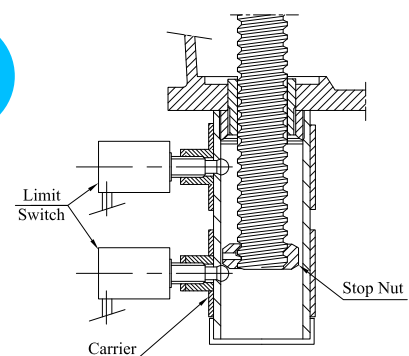

Stop Nut is provided to mechanically prevent over travel of the screw. Limit Switches can be provided to electrically set the upper and lower limit of travel of the screw. This is a very useful accessory for automation of a lifting system.

## ANTI-BACKLASH

An Internal Anti-Backlash Nut can be provided where it is critical to control the axial play of the Screw and Nut.

## OTHER VARIATIONS

Basically Screw Jack can be selected from the following 3 Basic Types depending upon the Application

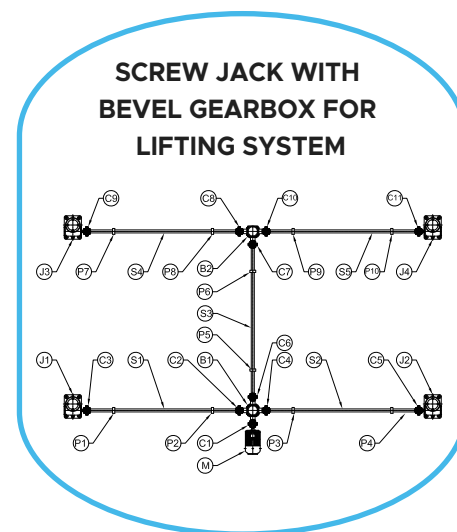
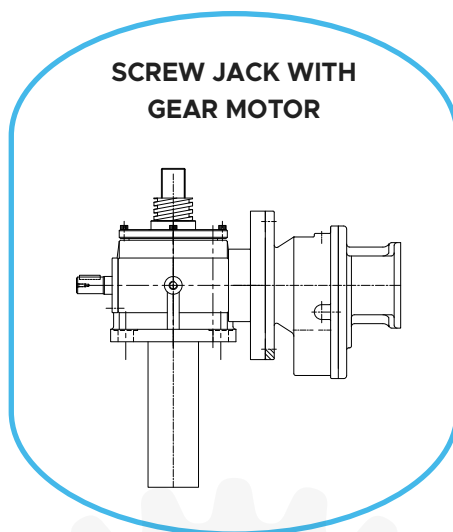
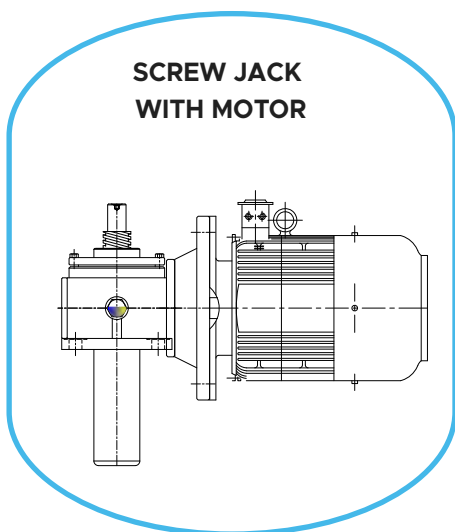

## TECHNICAL DATA

### Technical data, single start spindle

Size	0.5T	1.0 T	2.5T	5T	10T	20T	30T	50T
Max capacity KG	500	1000	2500	5000	10000	20000	30000	50000
Lifting screw	Tr 24x6	Tr 24x6	Tr 30x6	Tr 40x7	Tr 52x12	Tr 65x12	Tr 95x16	Tr 120x16
Ratio (L)	6:1	6:1	6:1	6:1	6:1	6:1	6:1	6:1
Raise per revolution of Input Shaft (mm)	1.0	1.0	1.0	1.16	2.0	2.0	2.6	2.6
Starting torque / Handwind torque at max load (Nm)	6	23	55	210	320	640	1280	2235
Max running power at 20% ED (kW)	0.2	0.55	0.9	1.5	2.9	3.7	5.1	12.5
Starting efficiency $\eta_s$	0.12	0.15	0.14	0.14	0.14	0.12	0.11	0.09
Ratio (H)	24:1	24:1	24:1	24:1	24:1	24:1	24:1	24:1
Raise per revolution of Input Shaft (mm)	0.25	0.25	0.25	0.29	0.5	0.5	0.65	0.65
Starting torque / Handwind torque at max load (Nm)	5	10	32	115	160	320	640	1335
Max running power at 20% ED (kW)	0.15	0.5	0.8	1.3	2.6	3.3	4.5	12
Starting efficiency $\eta_s$	0.05	0.08	0.06	0.06	0.07	0.06	0.05	0.05
Starting torque on lifting screw at max load (Nm)	21	77	199	810	1261	2548	5535	14425
Running efficiency $\eta_d$	0.2	0.25	0.25	0.25	0.25	0.25	0.25	0.25
Weight without spindle or protection tube (kg)								
Weight of lifting screw 100 mm (kg)								
Normal axial backlash (mm)	0.1-0.25	0.1-0.30	0.1-0.35	0.1-0.40	0.1-0.40	0.1-0.45	0.15-0.45	0.15-0.50